

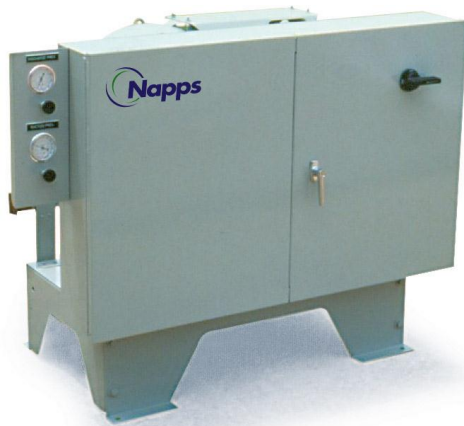

**APPLICATION MANUAL
FOR SCU SERIES COMPRESSOR UNITS AND
SWU SERIES WATER COOLED CONDENSING UNITS**



SCU-30



SWU-30

**Napps Technology Corporation
P.O. Box 3066
Longview, TX 75606-3066**

Phone: (903) 758-2900

FAX: (903) 758-2903

<http://www.nappstech.com>

sales@nappsac.com



Table of Contents

PRODUCT DESCRIPTION	3
GENERAL	3
COMPRESSOR	3
CONDENSER (SWU SERIES ONLY).....	3
CONTROL PANEL.....	3
REFRIGERATION CIRCUIT	3
UNIT ASSEMBLY	3
VIBRATION ISOLATION	4
OPTIONAL FEATURES	4
PRODUCT APPLICATION	4
PRODUCT SELECTION	4
UNIT LOCATION.....	4
CONDENSER WATER LIMITATIONS	4
CONDENSER WATER TREATMENT.....	4
WATER PUMPS	5
TABLE 1 - DIMENSIONS AND SPECIFICATIONS (SCU)	6
TABLE 2 - DIMENSIONS AND SPECIFICATIONS (SWU)	6
TABLE 3 - FULL LOAD PERFORMANCE (SCU)	7
TABLE 4 - FULL LOAD PERFORMANCE (SWU)	8
DIMENSIONAL & ELECTRICAL DATA	ERROR! BOOKMARK NOT DEFINED.
SCU-10 & SCU-15	ERROR! BOOKMARK NOT DEFINED.
SCU-20, SCU-25 & SCU-30	ERROR! BOOKMARK NOT DEFINED.
SCU-35, SCU-40 & SCU-45	9
SCU-50 & SCU-60	ERROR! BOOKMARK NOT DEFINED.
SWU-10 & SWU-15	10
SWU-20, SWU-25 & SWU-30	ERROR! BOOKMARK NOT DEFINED.
SWU-35, SWU-40 & SWU-45	11
SWU-50 & SWU-60	ERROR! BOOKMARK NOT DEFINED.
ELECTRICAL SCHEMATIC	13
UNITS WITH ONE COMPRESSOR	ERROR! BOOKMARK NOT DEFINED.
UNITS WITH TWO COMPRESSORS	ERROR! BOOKMARK NOT DEFINED.
UNITS WITH THREE COMPRESSORS	ERROR! BOOKMARK NOT DEFINED.
UNITS WITH FOUR COMPRESSORS	ERROR! BOOKMARK NOT DEFINED.
CONDENSER VESSEL WATER FLOW VS. PRESSURE DROP	17
ENGINEERING GUIDE SPECIFICATIONS	21
GENERAL	21
COMPRESSOR	21
CAPACITY (SCU)	21
CAPACITY (SWU)	21
CONDENSER (SWU ONLY).....	21
CONTROLS & CONTROL PANEL	21
REFRIGERANT CIRCUITS.....	21
SUPPORTING BASE	21
WARRANTY	22

Product Description

General

SCU Series Compressor Units and SWU Series Water Cooled Condensing Units are complete, factory assembled and tested products with integral refrigerant piping and control panel. Standard units are ready to be installed in an indoor area requiring only connection of electrical power wiring, control wiring from a remote temperature control and piping from remote system components. The SCU products require refrigeration line piping to a remote condenser (discharge line) and evaporator (suction line), while the SWU products require refrigerant piping to an evaporator (suction and liquid line) and water line piping (cooling water supply and return) to a cooling water source such as a cooling tower. All SCU and SWU product are equipped with crankcase heaters and pump out controls, and are available in either 208/230 volt, 60 hertz, 3 phase or 460 volt, 60 hertz, 3 phase models. All units are compact in size and will fit easily through a standard single-width door. Lifting rails are provided to facilitate hoisting and installation.

Compressor

Trane 3-D[®] Scroll Compressors, which are recognized throughout the industry for their high efficiency and reliability, are utilized on all SCU and SWU products. Compressors are hermetic 3600 rpm, direct-drive, fixed compression type with nominal capacities of 10 or 15 tons. Multiple compressors are used on units larger than 15 nominal tons. Each compressor has integral centrifugal oil pump, oil level sight-glass, oil charging valve, two point lubrication for each motor bearing, flooded lubrication for the journals and thrust bearings, and an outlet check valve on the scroll discharge port. Compressor motor is a hermetically sealed, two pole squirrel cage induction type that is cooled by suction gas.

Condenser (SWU Series only)

Condensers are cleanable through-tube type

with seamless carbon steel shell and integrally finned tubes that are roller expanded into the steel tube sheets. Condensers have field removable heads, which allow tube cleaning or replacement.

Condenser refrigerant (shell) side is constructed to the latest edition of the ASME Section VIII Division 1 code and stamped accordingly. Refrigerant side design pressure is 350 PSI at 250°F. Water (tube) side designed pressure is 300 PSI at 150°F. on single compressor SWU-10s and SWU-15s, and 150 PSI at 150°F on all other models. Both shell and tube sides of the condenser vessels are tested at 1.25 times the design pressure. Capacity ratings are based on a .0005 fouling factor.

Control Panel

Unit operating controls are contained within a single NEMA-1 enclosure. Inside the enclosure are the compressor contactors, compressor electronic overload relays, fused control power transformer, control relays, staging delay timers and a terminal strip. Standard safety controls include compressor current overload, compressor high temperature, high discharge pressure and low suction pressure.

Refrigeration Circuit

The refrigeration circuit includes a ball type shut off valve on the discharge line of all SCU models and on the liquid line of all SWU models. A ¼" access port is provided on the low and high side of all models. All SWU models also include a pressure relief valve mounted directly on the condenser vessel.

Unit Assembly

The complete unit is assembled on a 12 gauge galvanized steel base and painted with a topcoat of durable acrylic-enamel. All units are factory piped, wired, leak tested, electrically tested and shipped with a full operating charge of compressor oil and a holding charge of nitrogen.

Vibration Isolation

Compressor rails are mounted to the steel unit base using rubber isolators. Spring and neoprene-in-shear type isolators are available as a “ship loose” option for installations that are extremely sensitive to vibration. These optional isolators can be field installed under the unit base to further reduce vibration.

Optional Features

“Factory installed” options include 3-phase power monitor, cycle counter/hour-meter (one for each compressor), non-fused through-the-door panel mounted disconnect switch, refrigeration gauges with individual isolation valves, and hot gas bypass valve.

“Ship loose” options include suction line ball type shut off valves, water regulating valves (for use with SWU models), and neoprene and spring type isolators for both seismic and non-seismic applications.

Optional 5 year factory (Trane) extended compressor warranty is also available.

Product Application

Product Selection

Both SCU and SWU products are offered in 10 models each ranging in capacity from 10 to 60 nominal tons. Refer to Table 3 (SCU) or Table 4 (SWU) to select the model best suited for your application. Since actual unit capacity can vary significantly from “nominal capacity”, it is important to base your selection on the actual conditions. Selection of the correct model will require attention to the minimum, as well as the full load capacity required. If the minimum capacity required is less than the minimum capacity step of the unit (see Tables 1 & 2), the optional hot gas bypass valve may be added to abate an additional 5 tons of capacity. Selection of the proper equipment is an important part of a successful installation. Equipment sized too large will cycle more frequently and as a potential result lead to poor temperature and

humidity control, shortened equipment life and higher utility costs. Equipment sized too small will not be able to meet peak cooling demands.

Unit location

Units should be installed indoors or protected where exposure to rain or water splash is minimal. A level foundation or flooring must be provided which will support at least 150 percent of the operating weight of the unit. Service clearance must allow for removal of compressors. SWU products must also allow for removal of the condenser vessel. The unit foundation must be rigid to reduce vibration transmission to a minimum. Use of optional vibration isolators is recommended for applications that are sensitive to vibration and noise.

Condenser Water Limitations

SWU Water Cooled Condensing Units start and operate satisfactorily over a wide range of load conditions. Reducing the condenser water temperature below 85°F is an effective method of lowering the power input required. Beyond certain limits, however, the effect of further reducing condenser water temperature causes a reduction in the pressure drop across the thermal expansion valve to a point where system instability may occur. In general, continuous machine operation with entering condenser water temperature below 60°F is not recommended. When the condenser water temperature is expected to drop below 60°F, it is recommended that some form of condenser water temperature control be used to ensure optimal machine performance. Condenser water temperatures above 95°F are not recommended.

Condenser Water Treatment

Use of untreated or improperly treated condenser cooling water in any water cooled condensing unit may result in tube fouling, scaling, erosion, corrosion, algae, or slime; and, as a result cause reduced performance and increase the potential for unit failure. It is recommended that the services of a qualified

water treatment specialist be engaged to determine what condenser cooling water treatment and/or bleed-rate, if any, is advisable. NAPPS assumes no responsibility for the results of untreated or improperly treated water.

Water Pumps

Avoid specifying or using 3600 rpm condenser water and chilled water pumps. Such pumps may operate with objectionable noise and vibration. In addition, a low frequency beat may occur due to the slight difference in operating rpm between water pumps and the scroll compressors. Where noise and vibration-free operation is important, NAPPS encourages the use of 1750 rpm pumps.

Table 1 - Dimensions and Specifications (SCU)

NAPPS Model #	Dimensions			Operating Weight	Connection Size (Sweat)		Capacity Steps (% Capacity)	*MCA	
	L	W	H		Discharge	Suction		208/230 Volt	460 Volt
SCU-10	33"	28 1/2"	41 1/2"	360 lb.	7/8"	1 3/8"	N/A	53	23
SCU-15	33"	28 1/2"	41 1/2"	427 lb.	1 1/8"	1 5/8"	N/A	78	35
SCU-20	49 1/2"	28 1/2"	41 1/2"	570 lb.	1 1/8"	1 5/8"	100/50	95	42
SCU-25	49 1/2"	28 1/2"	41 1/2"	637 lb.	1 3/8"	2 1/8"	100/40	120	53
SCU-30	49 1/2"	28 1/2"	41 1/2"	704 lb.	1 3/8"	2 1/8"	100/50	140	63
SCU-35	60"	31 1/4"	50 1/2"	897 lb.	1 5/8"	2 1/8"	100/57/43	163	72
SCU-40	60"	31 1/4"	50 1/2"	964 lb.	1 5/8"	2 5/8"	100/63/37	183	81
SCU-45	60"	31 1/4"	50 1/2"	1031 lb.	1 5/8"	2 5/8"	100/67/33	203	90
SCU-50	80 1/4"	31 1/4"	50 1/2"	1224 lb.	2 1/8"	2 5/8"	100/70/40/30	225	99
SCU-60	80 1/4"	31 1/4"	50 1/2"	1358 lb.	2 1/8"	3 1/8"	100/75/50/25	265	118

* MCA @ 60 Hertz, 3φ

Table 2 - Dimensions and Specifications (SWU)

NAPPS Model #	Dimensions			Operating Weight	** Connection Sizes			Capacity Steps (% Capacity)	*MCA	
	L	W	H		Liqui d	Suction	Water		208/230 Volt	460 Volt
SWU-10	52"	28 1/2"	49 1/2"	620 lb.	7/8"	1 3/8"	1 1/4"	N/A	53	23
SWU-15	52"	28 1/2"	49 1/2"	697 lb.	7/8"	1 5/8"	1 1/4"	N/A	78	35
SWU-20	64"	28 1/2"	49 1/2"	875 lb.	1 1/8"	1 5/8"	2"	100/50	95	42
SWU-25	64"	28 1/2"	49 1/2"	952 lb.	1 1/8"	2 1/8"	2"	100/40	120	53
SWU-30	66"	28 1/2"	49 1/2"	1124 lb.	1 1/8"	2 1/8"	2 1/2"	100/50	140	63
SWU-35	66"	33 1/2"	61"	1327 lb.	1 3/8"	2 1/8"	2 1/2"	100/57/43	163	72
SWU-40	78"	33 1/2"	61"	1434 lb.	1 3/8"	2 5/8"	2 1/2"	100/63/37	183	81
SWU-45	69"	33 1/2"	61"	1621 lb.	1 3/8"	2 5/8"	3"	100/67/33	203	90
SWU-50	84"	33 1/2"	61"	1849 lb.	1 3/8"	2 5/8"	3"	100/70/40/30	225	99
SWU-60	84"	33 1/2"	61"	1983 lb.	1 3/8"	3 1/8"	3"	100/75/50/25	265	118

*MCA @ 60 Hertz, 3φ ** All refrigerant connections are sweat, all water connections are FPT,

Table 3 - Full Load Performance (SCU)

NAPPS Model #	Number of Compressors	SDT	Saturated Suction Temperature									
			30°F		35°F		40°F		45°F		50°F	
			Mbh	EER	Mbh	EER	Mbh	EER	Mbh	EER	Mbh	EER
SCU-10	1	105°F	107	13.4	119	14.8	131	16.2	144	17.8	158	19.4
		120°F	98	10.3	110	11.4	121	12.5	133	13.7	146	15.0
		130°F	92	8.6	103	9.5	113	10.5	125	11.5	137	12.6
SCU-15	1	105°F	159	13.2	176	14.6	194	16.0	214	17.5	234	19.1
		120°F	145	10.2	162	11.3	178	12.4	197	13.6	216	14.8
		130°F	136	8.5	152	9.4	168	10.4	185	11.4	204	12.5
SCU-20	2	105°F	212	13.3	235	14.6	258	16.0	284	17.5	311	19.1
		120°F	194	10.2	216	11.3	238	12.4	262	13.6	287	14.8
		130°F	181	8.5	202	9.4	223	10.3	246	11.3	271	12.4
SCU-25	2	105°F	262	13.1	291	14.5	321	15.8	353	17.3	386	18.9
		120°F	240	10.1	267	11.2	295	12.2	325	13.4	357	14.7
		130°F	224	8.4	250	9.3	277	10.3	305	11.3	336	12.3
SCU-30	2	105°F	313	13.0	348	14.4	383	15.7	421	17.2	462	18.8
		120°F	286	10.0	319	11.1	351	12.2	388	13.4	426	14.6
		130°F	267	8.4	299	9.3	330	10.2	364	11.2	401	12.3
SCU-35	3	105°F	362	12.9	403	14.3	443	15.6	487	17.1	534	18.7
		120°F	332	9.9	370	11.0	407	12.1	449	13.3	493	14.5
		130°F	310	8.3	346	9.2	382	10.1	422	11.1	464	12.2
SCU-40	3	105°F	412	12.8	458	14.2	504	15.6	554	17.0	608	18.6
		120°F	377	9.9	420	11.0	463	12.0	511	13.2	561	14.4
		130°F	352	8.3	394	9.2	435	10.1	480	11.1	528	12.1
SCU-45	3	105°F	462	12.8	514	14.1	565	15.5	622	17.0	682	18.6
		120°F	422	9.9	471	10.9	519	12.0	572	13.2	629	14.4
		130°F	395	8.2	441	9.2	488	10.1	538	11.1	592	12.1
SCU-50	4	105°F	516	12.9	574	14.2	631	15.6	694	17.1	761	18.6
		120°F	472	9.9	526	11.0	580	12.1	640	13.2	702	14.5
		130°F	442	8.3	493	9.2	545	10.1	601	11.1	661	12.2
SCU-60	4	105°F	616	12.8	685	14.1	754	15.5	829	17.0	909	18.6
		120°F	563	9.9	628	10.9	692	12.0	763	13.2	838	14.4
		130°F	526	8.2	588	9.2	650	10.1	718	11.1	790	12.1

Ratings are based on 60 Hz, R-22, 15° F subcooling and 20° F superheat per A.R.I. Standard 500-90

Table 4 - Full Load Performance (SWU)

Model # (number of compressors)	SST	Entering Condenser Water Temperature											
		75° F				85° F				95° F			
		Mbh	EER	GPM	Δ P	Mbh	EER	GPM	Δ P	Mbh	EER	GPM	Δ P
SWU-10 (1 compressor)	30° F	116	17.0	28.5	4.9	110	14.8	26.3	4.2	106	12.7	27.8	4.5
	40° F	140	20.4	31.5	5.9	134	17.6	32.3	6.0	128	15.1	33.0	6.2
	50° F	168	23.9	37.5	8.1	160	20.6	39.0	8.5	154	17.5	39.0	8.3
SWU-15 (1 compressor)	30° F	172	16.7	39.4	6.4	164	14.3	40.5	6.6	154	12.1	40.5	6.4
	40° F	208	19.9	47.3	8.9	200	17.3	48.4	9.1	188	14.4	48.4	8.9
	50° F	250	23.4	57.4	12.7	238	20.0	56.3	12.0	226	17.0	56.3	11.7
SWU-20 (2 compressors)	30° F	224	16.0	55.5	2.8	214	13.6	54.0	2.6	202	11.5	54.0	2.5
	40° F	272	18.9	64.5	3.7	260	16.2	63.0	3.4	246	13.7	61.5	3.2
	50° F	324	21.9	75.0	4.8	310	18.7	75.0	4.7	294	15.8	72.0	4.3
SWU-25 (2 compressors)	30° F	278	15.5	67.5	3.2	266	13.5	67.5	3.1	250	11.4	65.6	2.9
	40° F	336	18.5	80.6	4.4	320	15.8	78.8	4.1	304	13.3	76.9	3.8
	50° F	402	21.4	93.8	5.7	382	18.2	91.9	5.4	364	15.7	90	5.1
SWU-30 (2 Compressors)	30° F	336	15.9	81.6	2.3	318	13.6	81.6	2.2	300	11.5	79.1	2.1
	40° F	406	19.0	96.9	3.1	386	16.2	91.8	2.7	366	13.7	91.8	2.7
	50° F	485	22.0	112	4.0	465	19.1	109	3.8	440	16.2	107	3.5
SWU-35 (3 compressors)	30° F	386	15.6	94.4	3.0	366	13.3	91.8	2.7	346	11.2	91.8	2.7
	40° F	465	18.2	112	4.0	445	15.6	110	3.8	420	13.4	107	3.5
	50° F	555	21.4	130	5.3	530	18.3	127	5.0	505	15.5	125	4.7
SWU-40 (3 compressors)	30° F	440	15.8	108	4.2	420	13.4	107	4.1	396	11.4	104	3.8
	40° F	535	18.4	126	5.6	510	16.0	126	5.5	485	13.5	123	5.1
	50° F	640	21.7	148	7.5	605	18.5	145	7.0	575	15.7	142	6.6
SWU-45 (3 compressors)	30° F	495	15.7	124	2.4	470	13.4	120	2.2	445	11.3	116	2.0
	40° F	600	18.4	142	3.0	570	15.9	142	3.0	540	13.5	140	2.8
	50° F	715	21.6	169	4.1	680	18.5	165	3.9	650	15.9	161	3.6
SWU-50 (4 compressors)	30° F	555	16.0	137	3.2	530	13.7	132	2.9	500	11.6	132	2.9
	40° F	675	19.1	161	4.2	640	16.3	156	3.9	610	13.8	156	3.8
	50° F	800	22.1	189	5.7	770	19.2	184	5.3	730	16.3	180	4.9
SWU-60 (4 compressors)	30° F	660	15.7	161	4.2	625	13.4	156	3.9	590	11.3	156	3.8
	40° F	795	18.4	189	5.7	760	15.9	189	5.5	720	13.5	184	5.2
	50° F	955	21.6	222	7.6	910	18.5	217	7.1	860	15.6	213	6.7

Ratings are based on 60 Hz, R-22, 15° subcooling, 15° superheat, and 10° condenser water temperature rise in accordance with ARI standard 365-97

Dimensional & Electrical Data

SCU-10 & SCU-15

MODEL	PHYSICAL DATA			ELECTRICAL DATA - 208/230 VOLT, 3 ϕ , 60 HZ					ELECTRICAL DATA - 460 VOLT, 3 ϕ , 60HZ				
	"A"	"B"	OPERATING WEIGHT	COMPRESSOR RLA	COMPRESSOR LRA	MINIMUM CIRCUIT AMPACITY	MAXIMUM FUSE SIZE	RECOMMENDED TIME DELAY FUSE	COMPRESSOR RLA (EACH)	COMPRESSOR LRA (EACH)	MINIMUM CIRCUIT AMPACITY	MAXIMUM FUSE SIZE	RECOMMENDED TIME DELAY FUSE
SCU-10	1 3/8"	7/8"	360 LBS.	43	251	53	90	60	19	117	23	40	30
SCU-15	1 5/8"	1 1/8"	427 LBS.	63	376	78	125	90	28	178	35	60	40

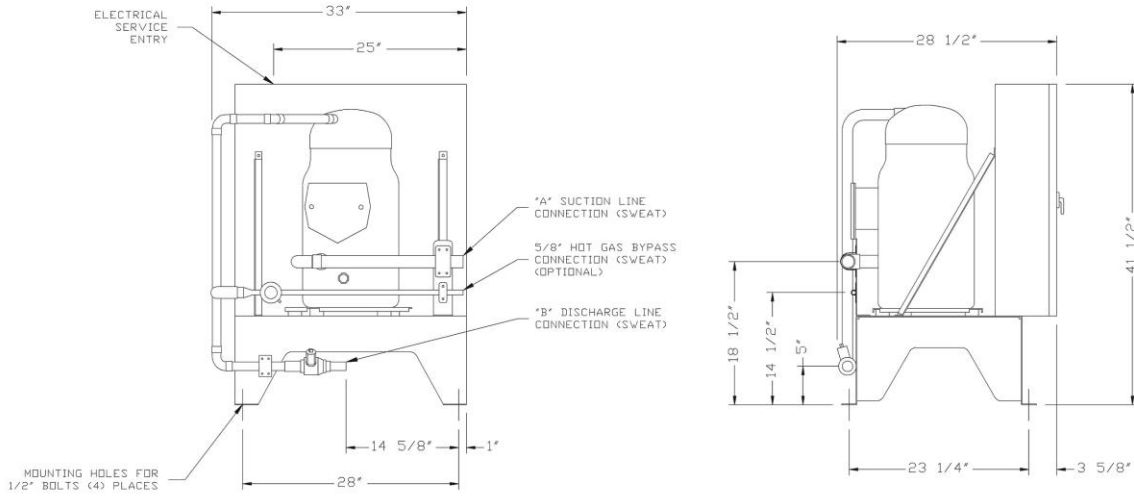

SCU-20, SCU-25 & SCU-30

MODEL	PHYSICAL DATA		ELECTRICAL DATA - 208/230 VOLT, 3 ϕ , 60 HZ					ELECTRICAL DATA - 460 VOLT, 3 ϕ , 60HZ				
	"A"	OPERATING WEIGHT	COMPRESSOR RLA (EACH)	COMPRESSOR LRA (EACH)	MINIMUM CIRCUIT AMPACITY	MAXIMUM FUSE SIZE	RECOMMENDED TIME DELAY FUSE	COMPRESSOR RLA (EACH)	COMPRESSOR LRA (EACH)	MINIMUM CIRCUIT AMPACITY	MAXIMUM FUSE SIZE	RECOMMENDED TIME DELAY FUSE
SCU-20	1 5/8"	570 LBS.	43/43	251/251	95	125	110	19/19	117/117	42	60	50
SCU-25	2 1/8"	637 LBS.	43/63	251/376	120	175	150	19/28	117/178	53	80	60
SCU-30	2 1/8"	704 LBS.	63/63	376/376	140	200	175	28/28	178/178	63	90	70

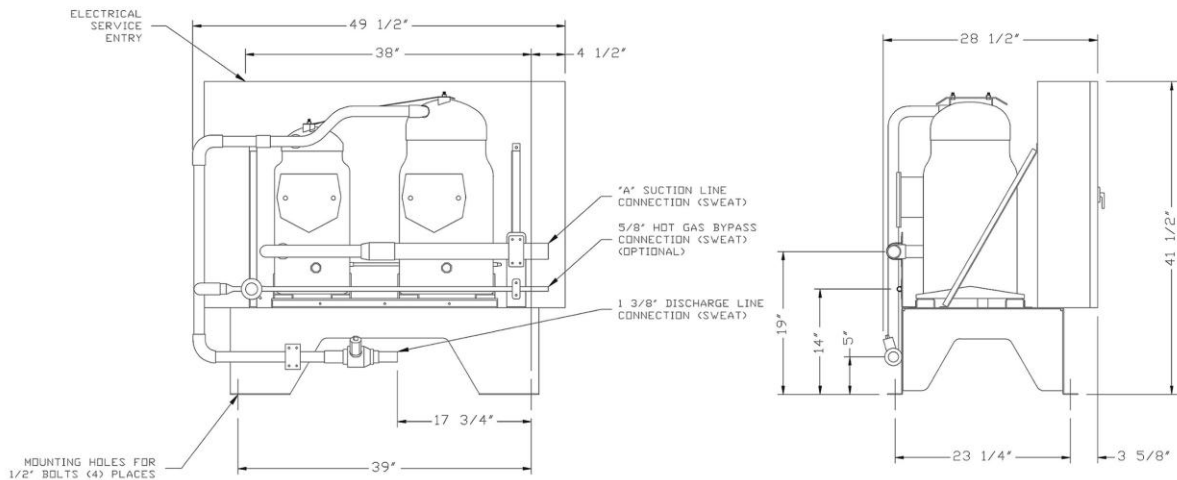

SCU-35, SCU-40 & SCU-45

MODEL	PHYSICAL DATA		ELECTRICAL DATA - 208/230 VOLT, 3 ϕ , 60 HZ						ELECTRICAL DATA - 460 VOLT, 3 ϕ , 60HZ			
	"A"	OPERATING WEIGHT	COMPRESSOR RLA (EACH)	COMPRESSOR LRA (EACH)	MINIMUM CIRCUIT AMPACITY	MAXIMUM FUSE SIZE	RECOMMENDED TIME DELAY FUSE	COMPRESSOR RLA (EACH)	COMPRESSOR LRA (EACH)	MINIMUM CIRCUIT AMPACITY	MAXIMUM FUSE SIZE	RECOMMENDED TIME DELAY FUSE
SCU-35	2 1/8"	897 LBS.	43/43/63	251/251/376	163	225	175	19/19/28	117/117/178	72	100	80
SCU-40	2 5/8"	964 LBS.	43/63/63	251/376/376	183	225	200	19/26/28	117/178/178	81	110	90
SCU-45	2 5/8"	1031 LBS.	63/63/63	376/376/376	203	250	225	28/26/28	178/178/178	90	110	100

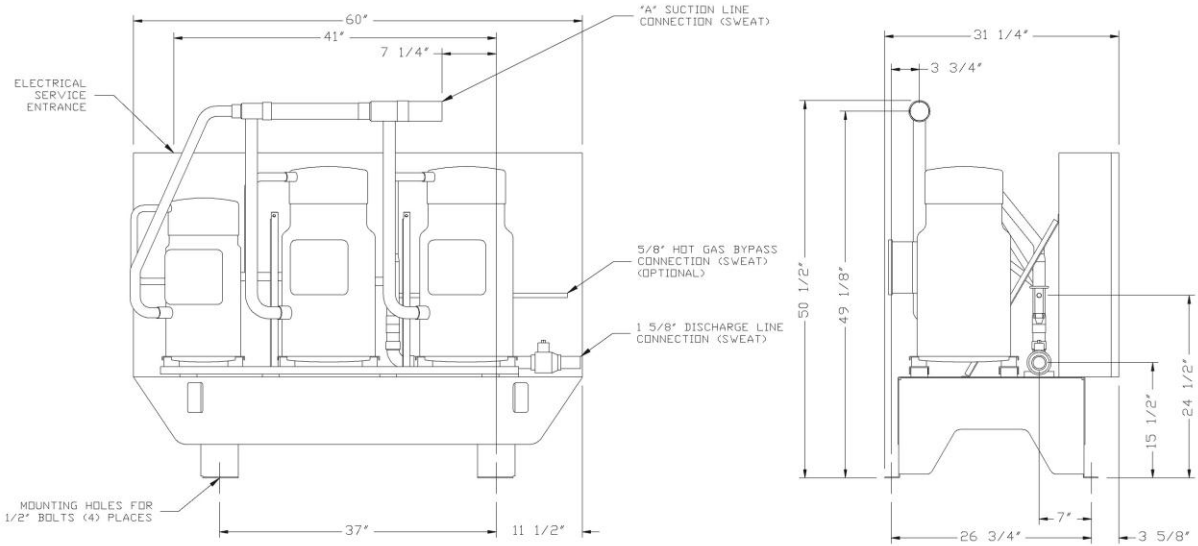

SCU-50 & SCU-60

MODEL	PHYSICAL DATA		ELECTRICAL DATA - 208/230 VOLT, 3 ϕ , 60 HZ					ELECTRICAL DATA - 460 VOLT, 3 ϕ , 60HZ				
	"A"	OPERATING WEIGHT	COMPRESSOR RLA (EACH)	COMPRESSOR LRA (EACH)	MINIMUM CIRCUIT AMPACITY	MAXIMUM FUSE SIZE	RECOMMENDED TIME DELAY FUSE	COMPRESSOR RLA (EACH)	COMPRESSOR LRA (EACH)	MINIMUM CIRCUIT AMPACITY	MAXIMUM FUSE SIZE	RECOMMENDED TIME DELAY FUSE
SCU-50	2 5/8"	1224 LBS.	63/63/43/43	376/376/251/251	225	250	250	28/28/19/19	178/178/117/117	99	125	110
SCU-60	3 1/8"	1358 LBS.	63/63/63/63	376/376/376/376	265	300	300	28/28/28/28	178/178/178/178	118	125	125

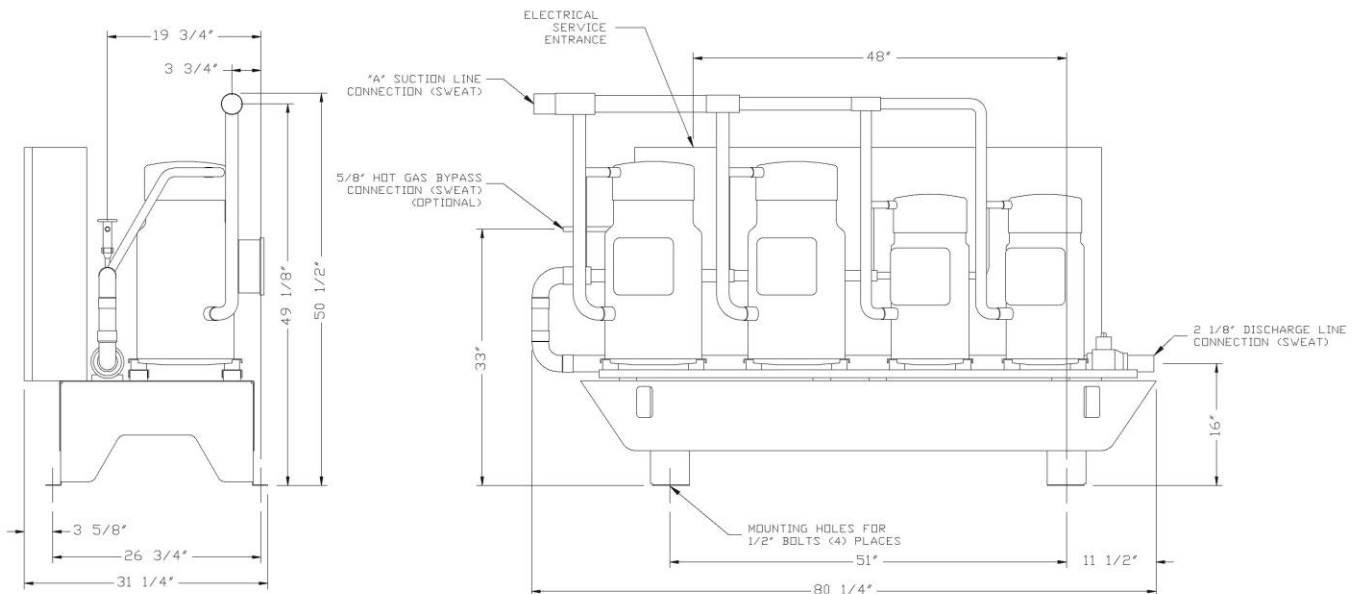

SWU-10 & SWU-15

MODEL	PHYSICAL DATA		ELECTRICAL DATA - 208/230 VOLT, 3 ϕ , 60 HZ					ELECTRICAL DATA - 460 VOLT, 3 ϕ , 60HZ				
	"A"	OPERATING WEIGHT	COMPRESSOR RLA	COMPRESSOR LRA	MINIMUM CIRCUIT AMPACITY	MAXIMUM FUSE SIZE	RECOMMENDED TIME DELAY FUSE	COMPRESSOR RLA	COMPRESSOR LRA	MINIMUM CIRCUIT AMPACITY	MAXIMUM FUSE SIZE	RECOMMENDED TIME DELAY FUSE
SWU-10	1 3/8"	620 LBS.	43	251	53	90	60	19	117	23	40	30
SWU-15	1 5/8"	697 LBS.	63	376	78	125	90	28	178	35	60	45

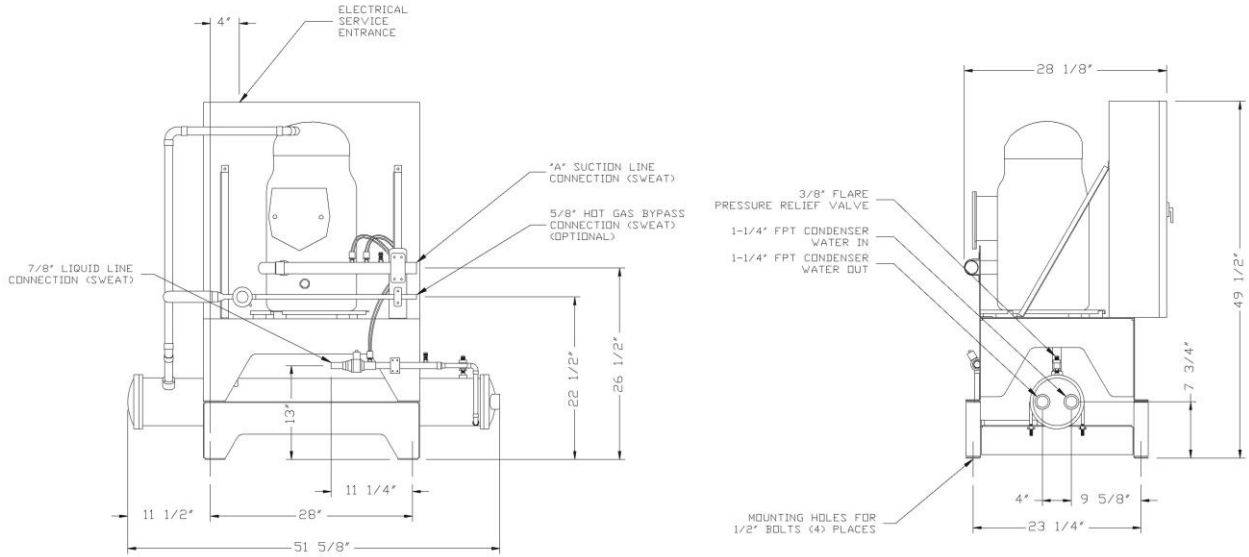

SWU-20, SWU-25 & SWU-30

MODEL	PHYSICAL DATA						ELECTRICAL DATA - 208/230 VOLT, 3 ϕ , 60 HZ					ELECTRICAL DATA - 460 VOLT, 3 ϕ , 60HZ					
	"A"	"B"	"C"	"D"	"E"	"F"	OPERATING WEIGHT	COMPRESSOR RLA (EACH)	COMPRESSOR LRA (EACH)	MINIMUM CIRCUIT AMPACITY	MAXIMUM FUSE SIZE	RECOMMENDED TIME DELAY FUSE	COMPRESSOR RLA (EACH)	COMPRESSOR LRA (EACH)	MINIMUM CIRCUIT AMPACITY	MAXIMUM FUSE SIZE	RECOMMENDED TIME DELAY FUSE
SWU-20	64"	12 1/2"	6 3/8"	2 7/8"	2" FPT	1 5/8"	875 LBS.	43/43	251/251	95	125	110	19/19	117/117	42	60	50
SWU-25	64"	12 1/2"	6 3/8"	2 7/8"	2" FPT	2 1/8"	952 LBS.	43/63	251/376	120	175	150	19/28	117/178	53	80	60
SWU-30	66"	13 1/2"	7"	3 3/4"	2 1/2" FPT	2 1/8"	1124 LBS.	63/63	376/376	140	200	175	28/28	178/178	63	90	70

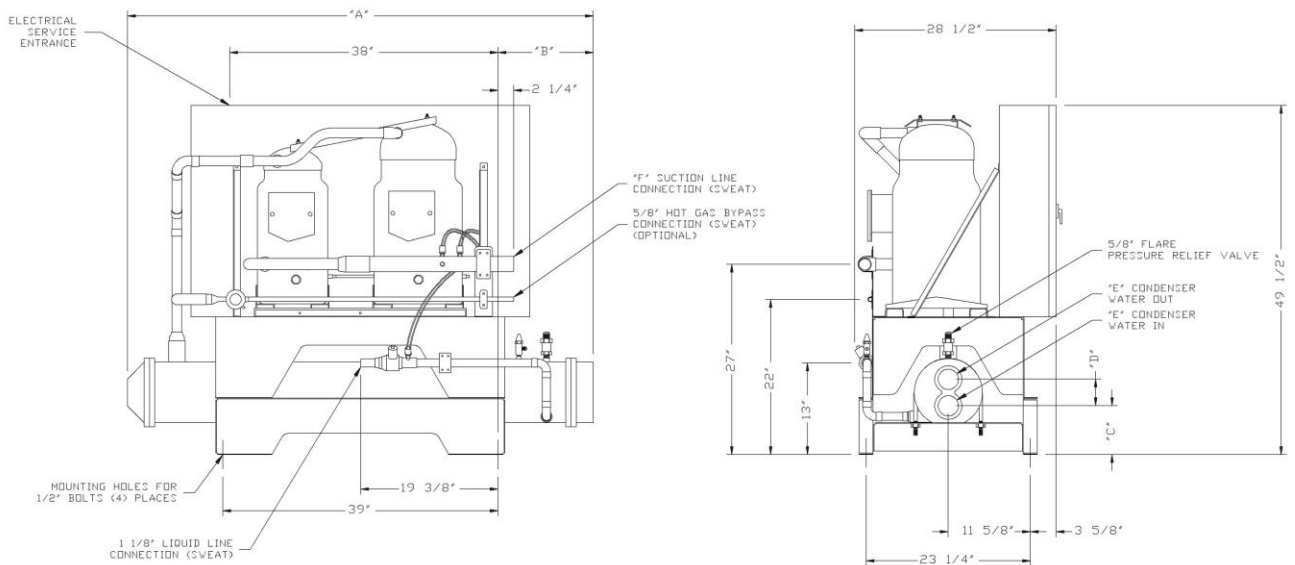

SWU-35, SWU-40 & SWU-45

MODEL	PHYSICAL DATA						ELECTRICAL DATA - 208/230 VOLT, 3 ϕ , 60 HZ					ELECTRICAL DATA - 460 VOLT, 3 ϕ , 60HZ					
	"A"	"B"	"C"	"D"	"E"	"F"	OPERATING WEIGHT	COMPRESSOR RLA (EACH)	COMPRESSOR LRA (EACH)	MINIMUM CIRCUIT AMPACITY	MAXIMUM FUSE SIZE	RECOMMENDED TIME DELAY FUSE	COMPRESSOR RLA (EACH)	COMPRESSOR LRA (EACH)	MINIMUM CIRCUIT AMPACITY	MAXIMUM FUSE SIZE	RECOMMENDED TIME DELAY FUSE
SWU-35	66"	14 1/2"	8"	3 3/4"	2 3/8" FPT	2 1/8"	1327 LBS.	43/43/63	251/251/376	163	225	175	19/19/28	117/117/178	72	100	80
SWU-40	78"	20 1/2"	8"	3 3/4"	2 3/8" FPT	2 5/8"	1434 LBS.	43/63/63	251/376/376	183	225	200	19/28/28	117/178/178	81	110	90
SWU-45	89 1/8"	16 1/16"	8 5/8"	4 1/2"	3" FPT	2 5/8"	1621 LBS.	63/63/63	376/376/376	203	250	225	28/28/28	178/178/178	90	110	100

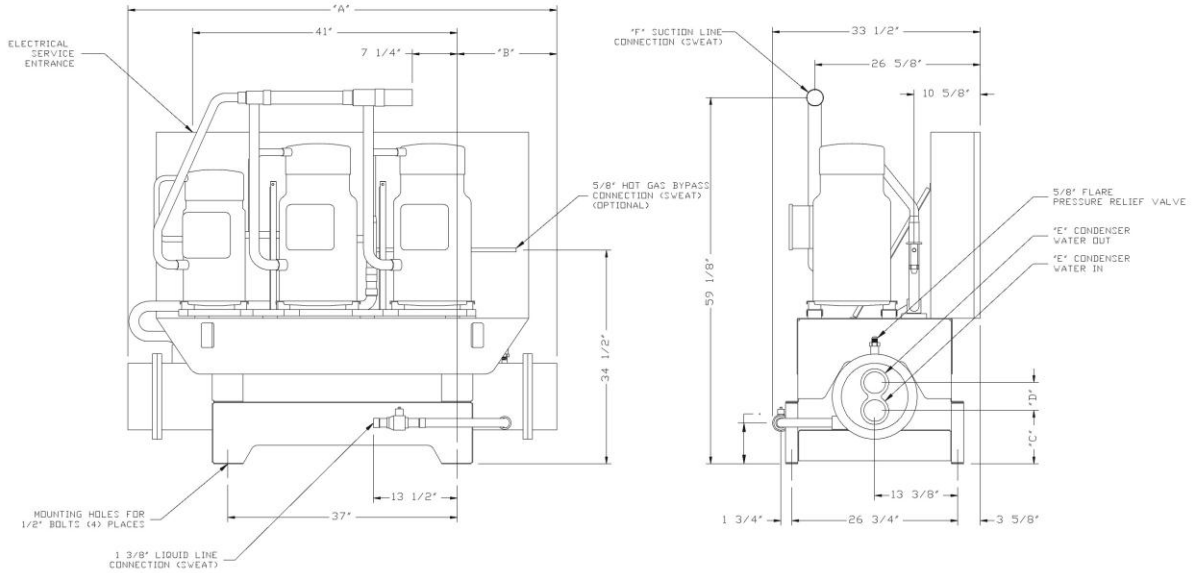

SWU-50 & SWU-60

MODEL	PHYSICAL DATA		ELECTRICAL DATA - 208/230 VOLT, 3 ϕ , 60 HZ					ELECTRICAL DATA - 460 VOLT, 3 ϕ , 60HZ				
	"A"	OPERATING WEIGHT	COMPRESSOR RLA (EACH)	COMPRESSOR LRA (EACH)	MINIMUM CIRCUIT AMPACITY	MAXIMUM FUSE SIZE	RECOMMENDED TIME DELAY FUSE	COMPRESSOR RLA (EACH)	COMPRESSOR LRA (EACH)	MINIMUM CIRCUIT AMPACITY	MAXIMUM FUSE SIZE	RECOMMENDED TIME DELAY FUSE
SWU-50	2 5/8"	1849 LBS.	63/63/43/43	376/376/251/251	225	250	250	28/28/19/19	178/178/117/117	99	125	110
SWU-60	3 1/8"	1983 LBS.	63/63/63/63	376/376/376/376	265	300	300	28/28/28/28	178/178/178/178	118	125	125

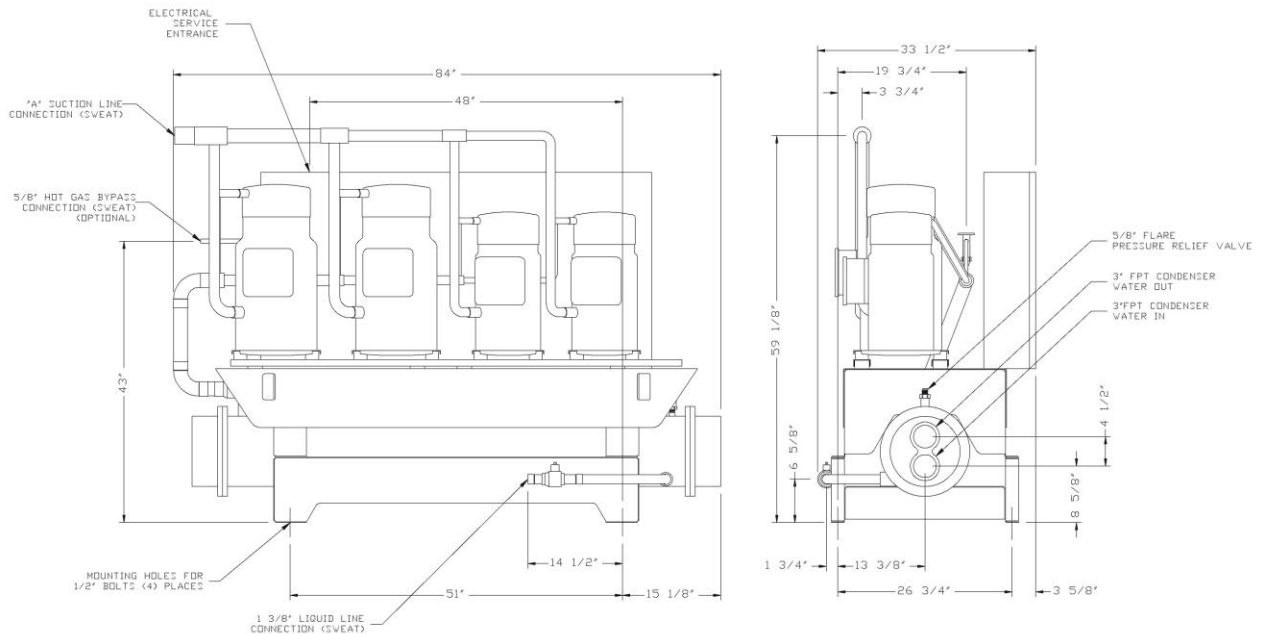

Electrical Schematic

Units With One Compressor

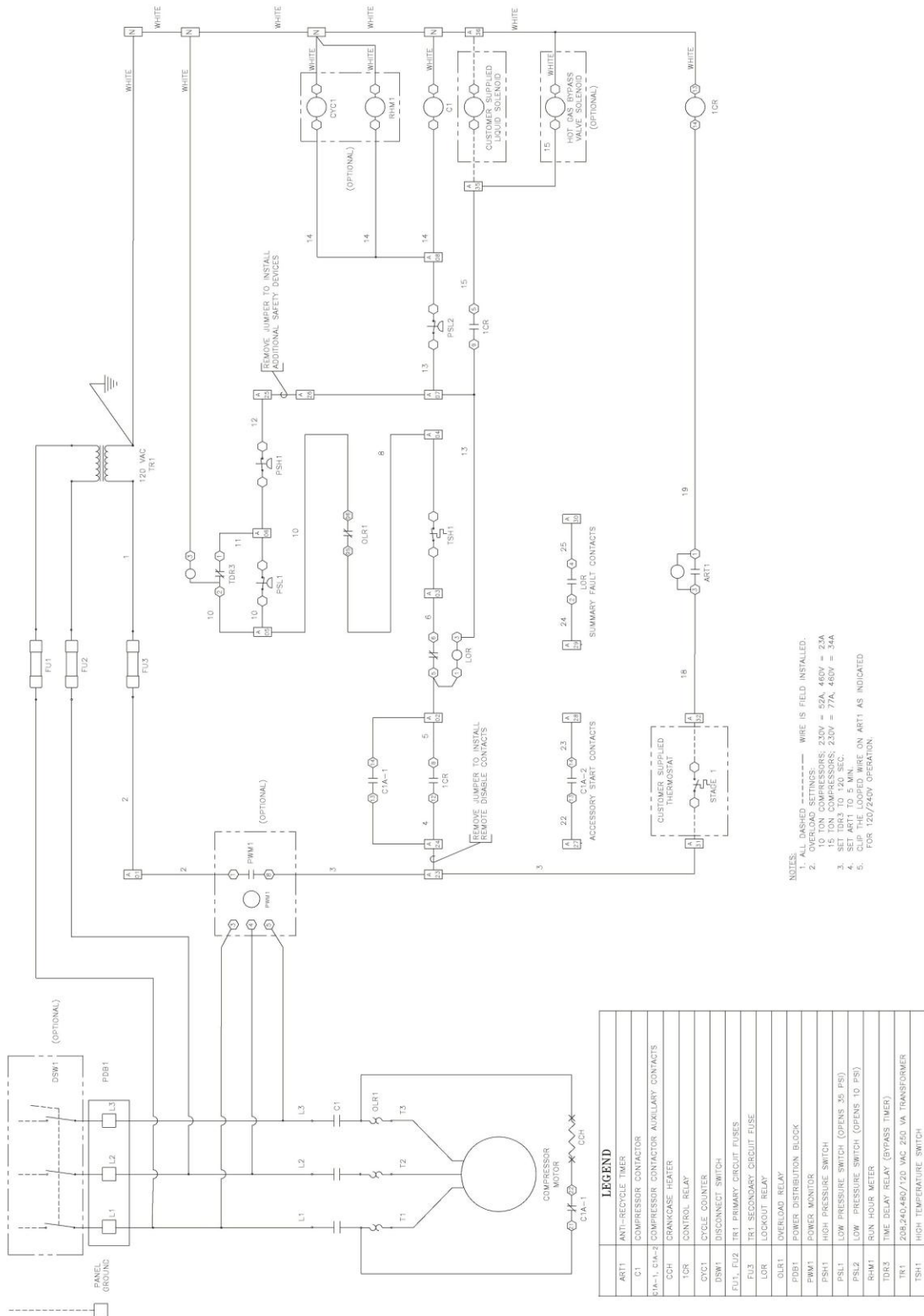

Units With Two Compressor

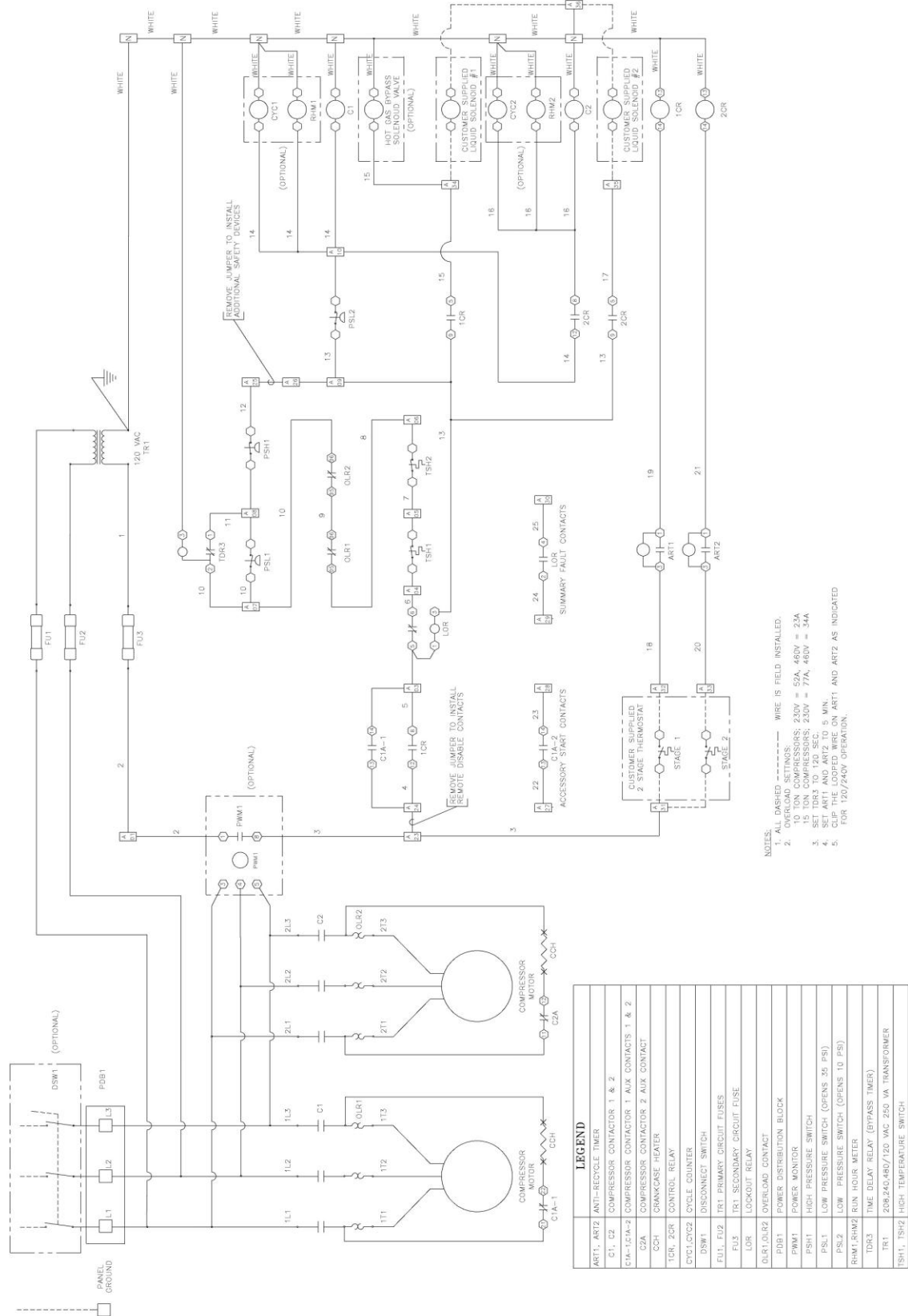

Units With Three Compressors

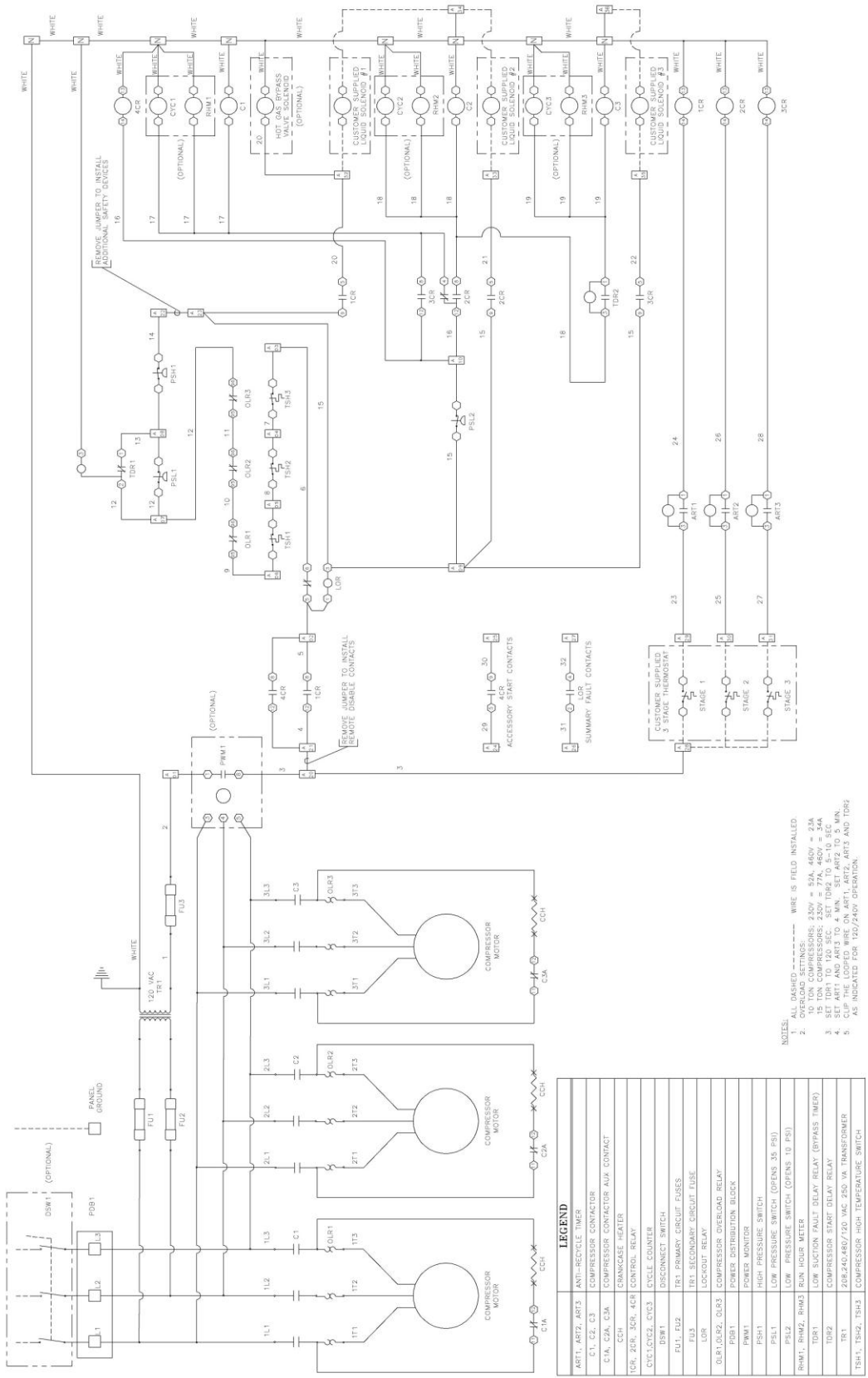

- NOTES:**
1. ALL DASHED LINES INDICATE WIRE IS FIELD INSTALLED.
 2. 10 TON COMPRESSORS 230V = 32A, 480V = 23A
 3. 15 TON COMPRESSORS 230V = 37A, 480V = 34A
 4. SET ART1 AND ART2 TO 4 MIN, SET ART3 TO 5 MIN.
 5. CLIP THE LOOPED WIRE ON ART1, ART2, ART3 AND TOR3 AS INDICATED FOR 120V/240V OPERATION.

LEGEND	
ART1, ART2, ART3	ANTI-RECYCLE TIMER
C1, C2, C3	COMPRESSOR CONTACTOR
C1A, C2A, C3A	COMPRESSOR CONTACTOR AUX CONTACT
CCH	CRANKCASE HEATER
TCR, ZCR, SCR, 4CR	CONTROL RELAY
CYC1, CYC2, CYC3	CYCLE COUNTER
DSW1	DISCONNECT SWITCH
EUS	TR1 PRIMARY CIRCUIT FUSES
FU1, FU2	TR1 SECONDARY CIRCUIT FUSES
LOR	LOCKOUT RELAY
OLR1, OLR2, OLR3	COMPRESSOR OVERLOAD RELAY
PSB1	POWER DISTRIBUTION BLOCK
PSM1	POWER MONITOR
PSH1	HIGH PRESSURE SWITCH
PSL1	LOW PRESSURE SWITCH (OPENS 30 PSI)
PSL2	LOW PRESSURE SWITCH (OPENS 10 PSI)
RHM1, RHM2, RHM3	ROOM HOUR METER
TOR1	LOW SUCTION FAULT DELAY RELAY (BYPASS TIMER)
TOR2	COMPRESSOR START DELAY RELAY
TR1	ZUR-240-480/720 VAC 250 VA TRANSFORMER
TSH1, TSH2, TSH3	COMPRESSOR HIGH TEMPERATURE SWITCH

Units With Four Compressors

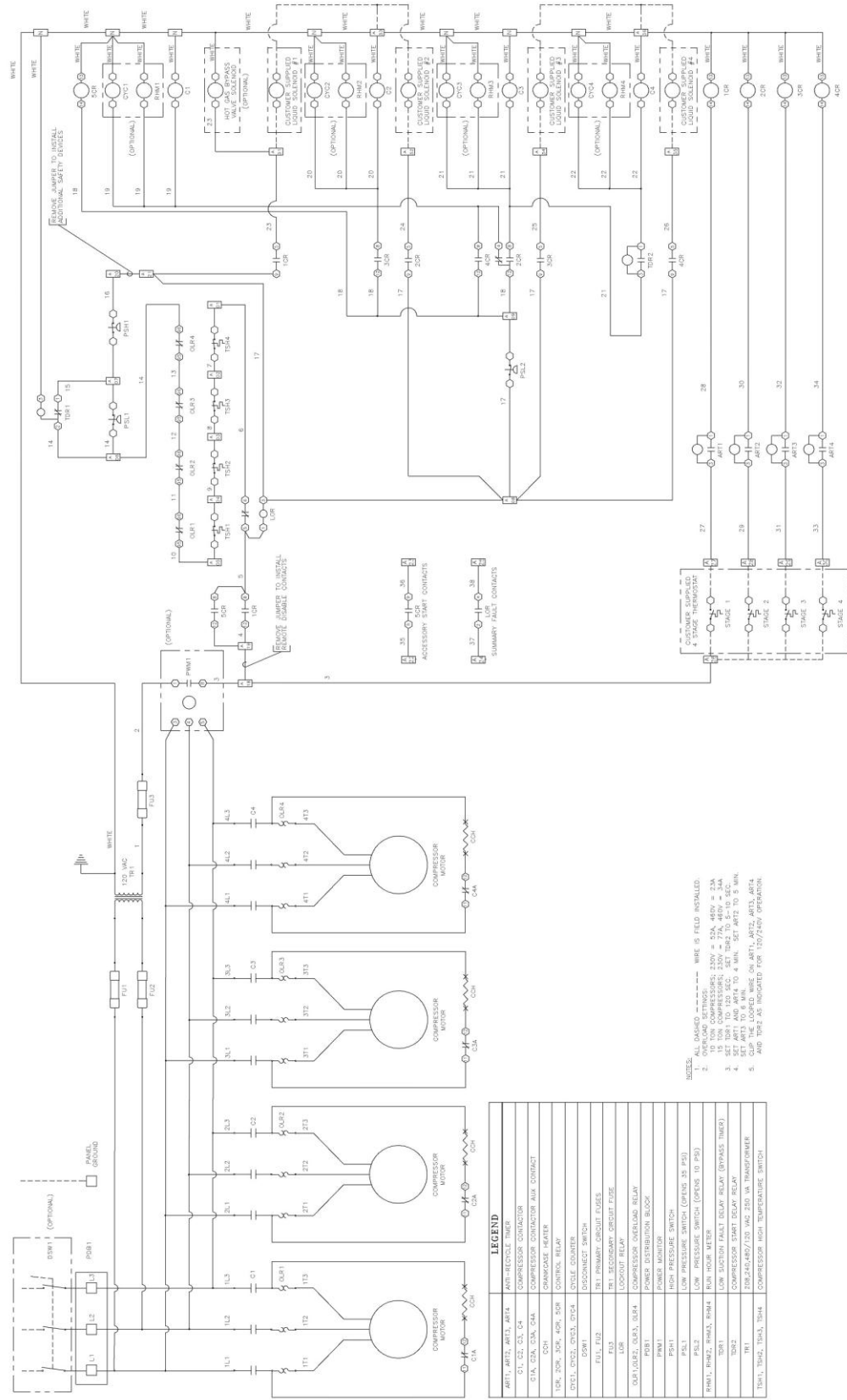

Condenser Vessel Water Flow vs. Pressure Drop

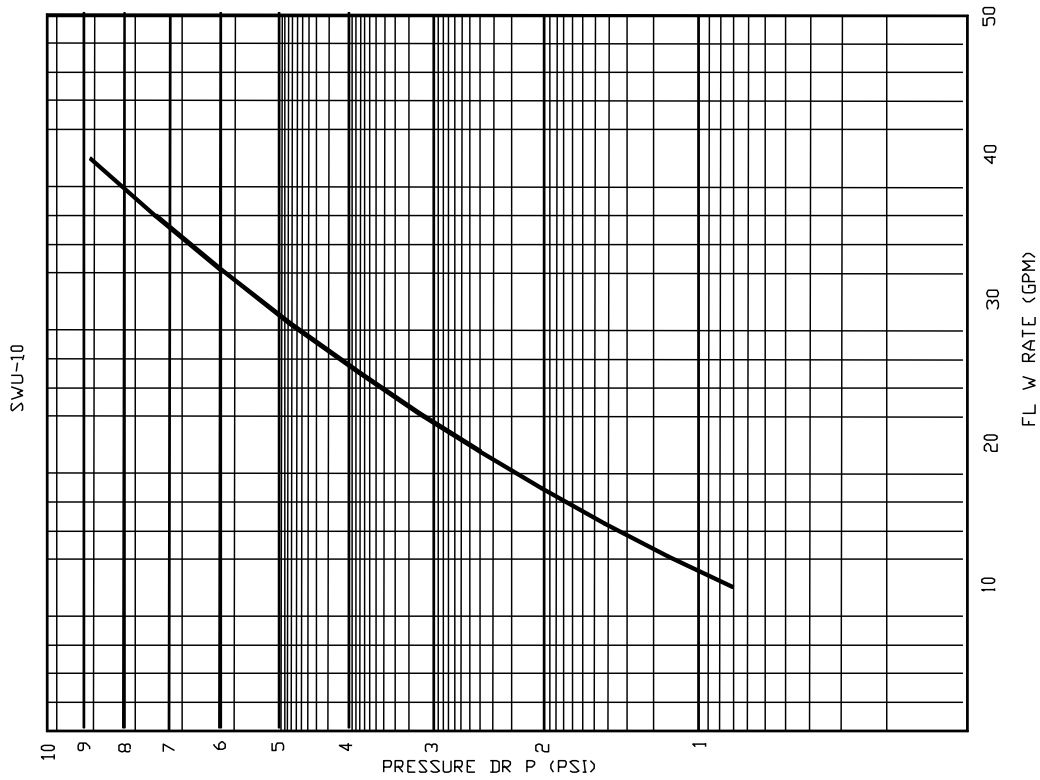
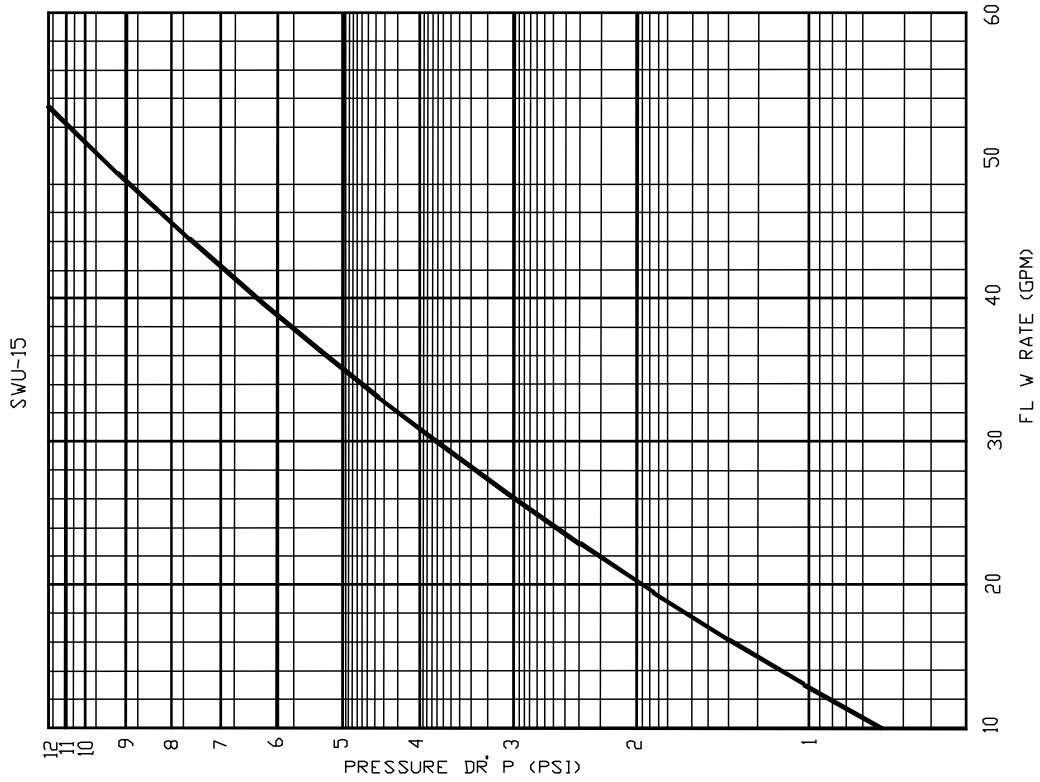

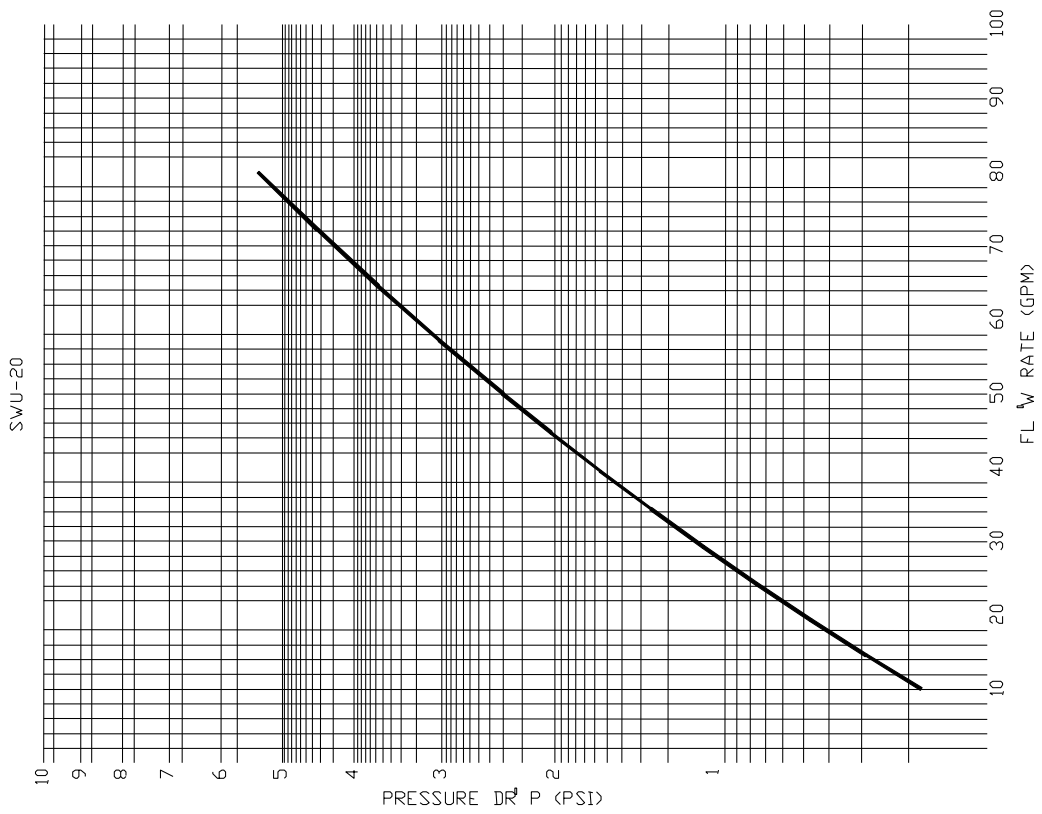
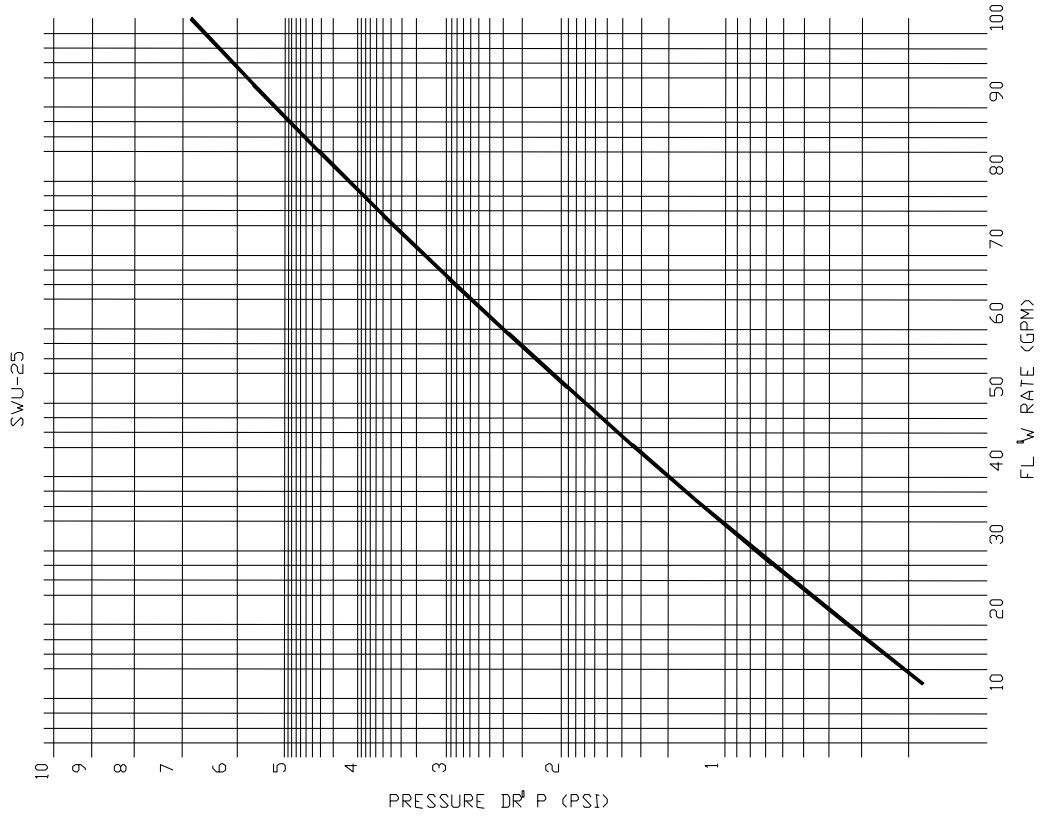

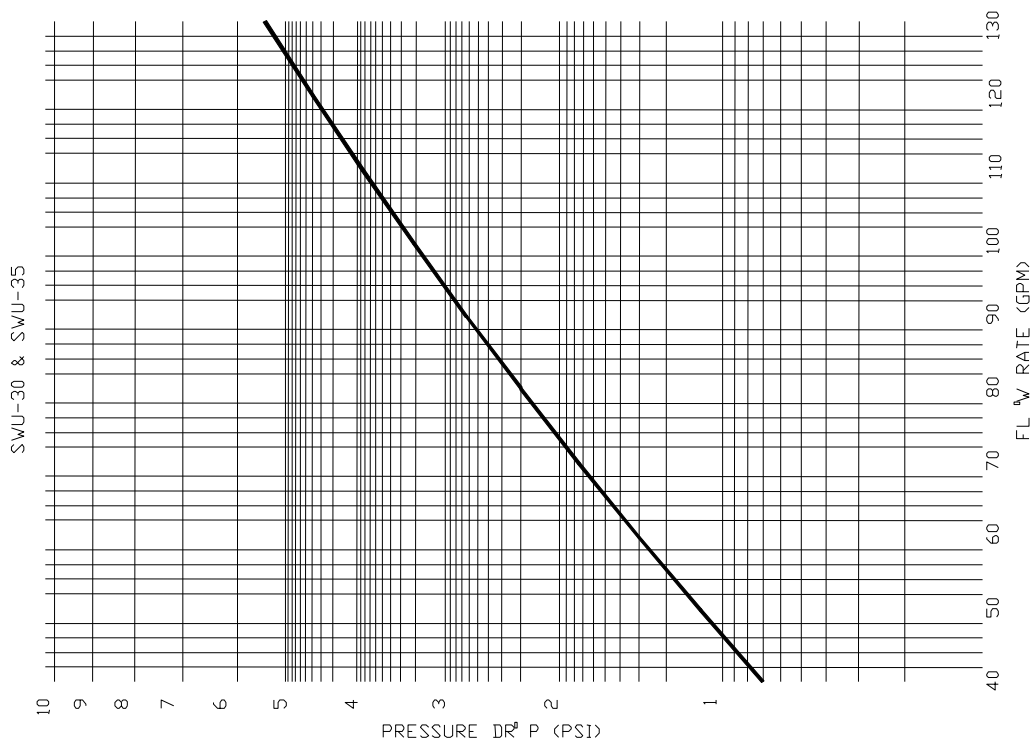
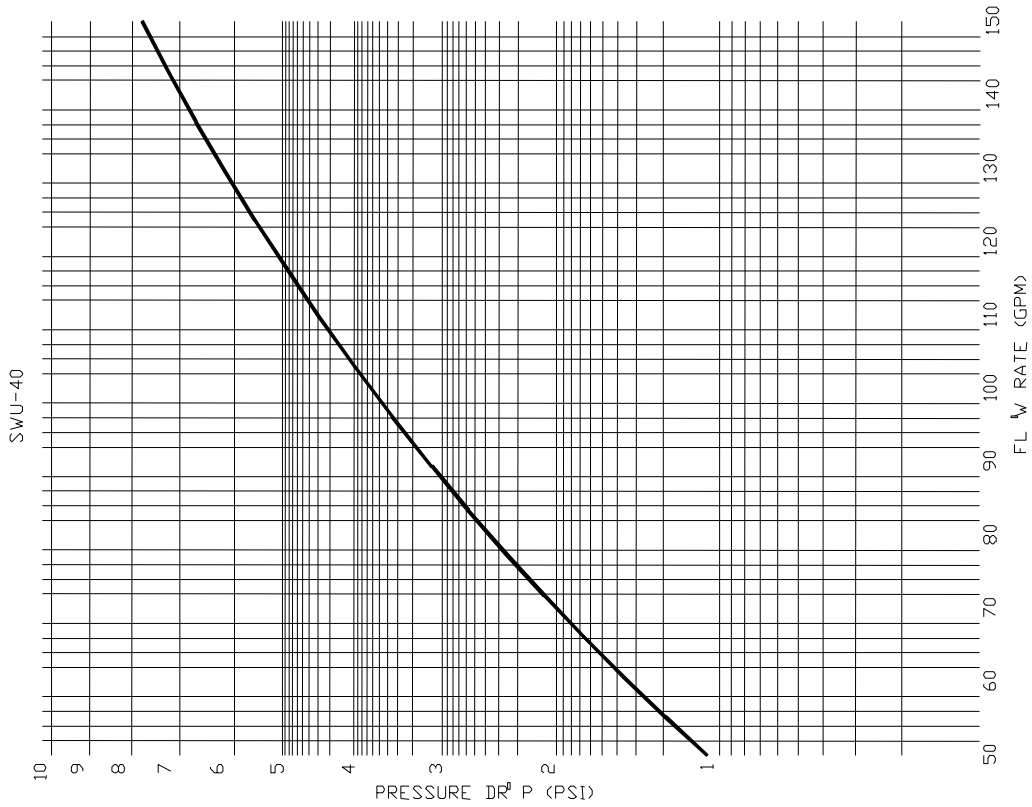

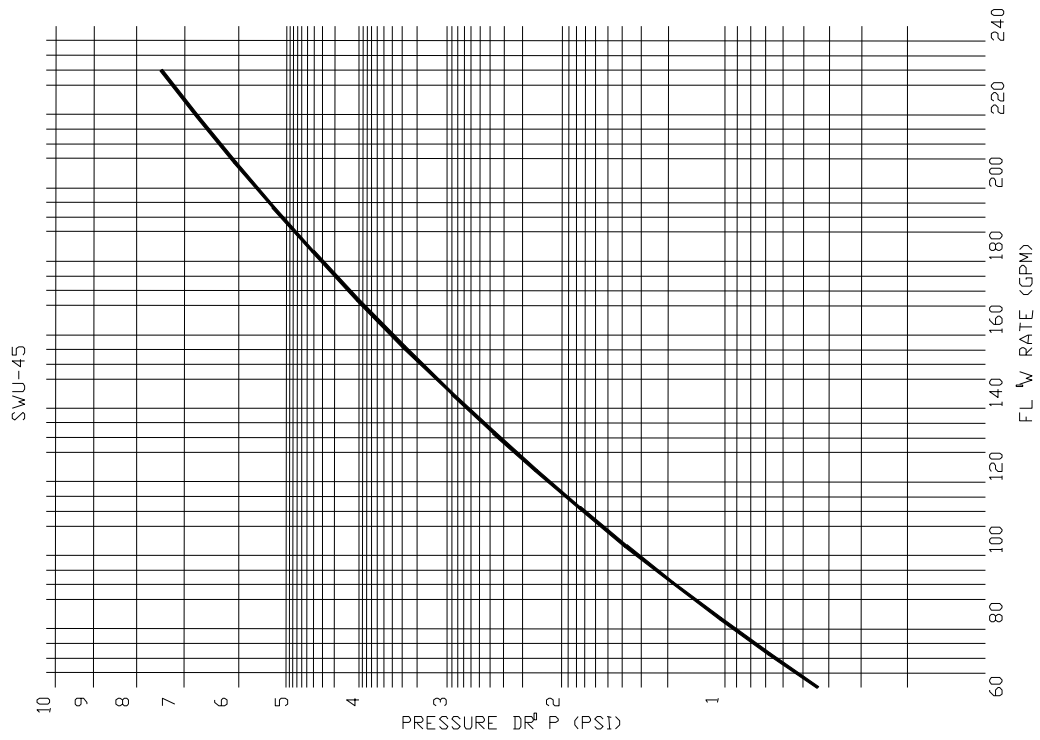
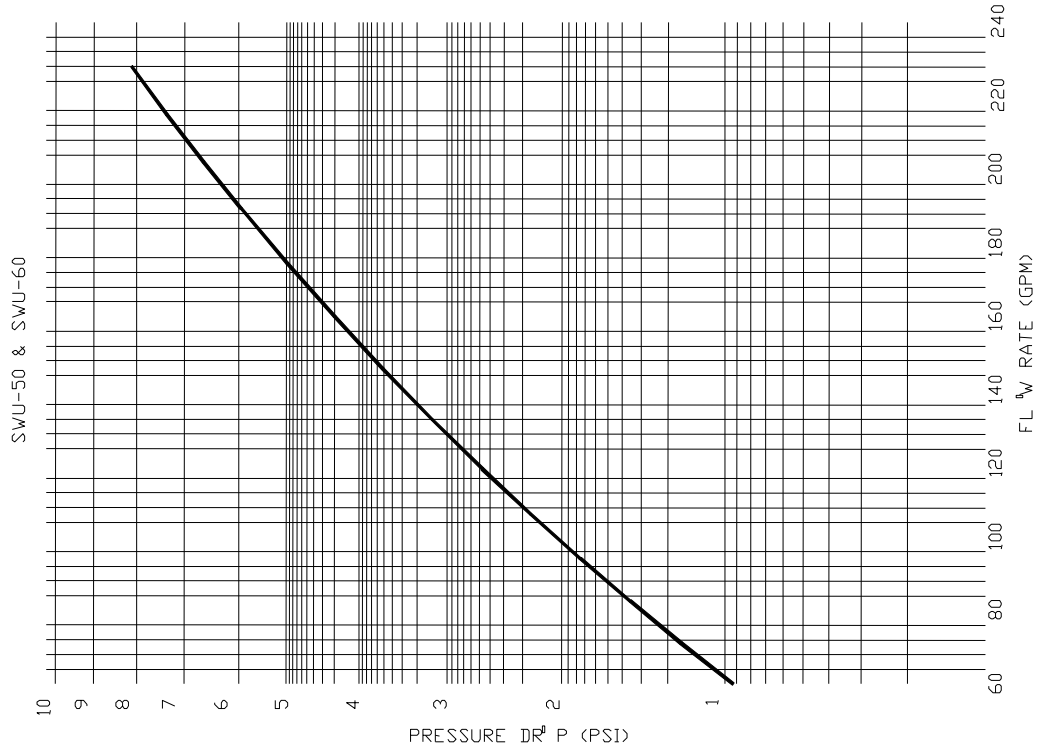

Engineering Guide

Specifications

General

Model _____ unit shall be a standard production factory assembled model and shall bear the ETL Listing Mark as a complete package. Each unit shall undergo a complete factory control sequence test and shall be shipped with a full operating charge of compressor oil and a holding charge of nitrogen. All exposed surfaces shall be primed and top coated with a finish coat of acrylic-enamel. Unit shall not exceed _____ inches in length, _____ inches in width, and _____ inches in height. Unit operating weight shall not exceed _____ lbs.

Compressor

The compressor(s) shall be direct-drive, hermetic, 3600 rpm, fixed compression, scroll type. Compressor nominal capacity shall be 10 or 15 tons, and units shall employ multiple compressors to achieve capacities above 15 nominal tons. Compressor shall include centrifugal oil pump, oil level sight-glass, oil charging valve, two point lubrication for each motor bearing, flooded lubrication for the journal and thrust bearings, and an outlet check valve on the scroll discharge port. Compressor motor shall be suction gas cooled, hermetically sealed, two pole squirrel cage induction type.

Capacity (SCU)

The Compressor Unit shall have a capacity of _____ Mbh when operating at _____ °F saturated condensing temperature and _____ °F saturated suction temperature. Unit full load cooling EER at these conditions shall be no less than _____.

Capacity (SWU)

The Water Cooled Condensing Unit shall have a capacity of _____ Mbh when operating at _____ °F saturated suction temperature and supplied with _____ gpm of _____ °F condenser water. Water pressure drop shall not exceed _____ psi through the condenser. Unit full load

cooling EER at these conditions shall be no less than _____.

Condenser (SWU Only)

Condenser shall be serviceable, through tube type with steel shell and high performance $\frac{3}{4}$ " OD integrally finned copper tubes. All tubes shall be roller expanded into multi-grooved steel tube sheets. Condenser shall be rated no less than 350 psig shell side and no less than 150 psig tube side, and shall include a refrigerant pressure relief valve. Condenser refrigerant side shall be constructed in accordance with the latest edition of Section VIII, Division I of ASME Code for Pressure Vessels and stamped accordingly.

Controls & Control Panel

The electrical controls shall be mounted in a totally enclosed steel cabinet and factory wired to control terminal strips with provision for controlling system accessories, adding safety devices, allowing remote enable/disable, and providing remote summary fault annunciation. Unit shall automatically pump-out when cycled off. Compressors shall have crankcase heaters connected to cycle on when compressors are not running. Safety shut down of the unit shall be provided in the event of high discharge pressure, low suction pressure, high compressor temperature and compressor over-current. All controls and enclosures are to conform to applicable codes.

Refrigerant Circuits

The refrigerant circuit shall include high side ball type shut-off valve, $\frac{1}{4}$ " access valves on both the high and low side, and a pressure relief valve on the condenser vessel of SWU products. Unit shall be shipped with a full operating charge of compressor oil and a holding charge of nitrogen.

Supporting Base

Complete unit shall be assembled on a rigid steel base. Unit base shall be constructed of 12 Ga. galvanized steel with the surface etched for paint adhesion. All compressors shall be mounted on the base frame using rubber vibration absorbing isolators.

Warranty

I. LIMITED PRODUCT WARRANTY & SERVICE POLICY

Napps Industries, Inc. (NAPPS) warrants for a period of twelve (12) months from date of original shipment that all products, manufactured by NAPPS, with the exception of packaged refrigeration products, are free from defects of material and workmanship when used within the service, range, and purpose for which they were manufactured. Packaged refrigeration products shall be so warranted for a period of twelve (12) months from date of start-up or eighteen (18) months from date of original shipment, whichever may first occur. Service Parts shall be so warranted for a period of ninety (90) days from date of installation, or twelve (12) months from date of original shipment, whichever may first occur.

In case material is rejected on inspection by the buyer as defective, NAPPS shall be notified in writing within ten (10) days from receipt of said material. NAPPS will then have the option of re-inspection at the buyer's plant or its own plant before allowing or rejecting the buyer's claim. Expenses incurred in connection with claims for which NAPPS is not liable may be charged back to the buyer. No claim for correction will be allowed for work done in the field except with the written consent of NAPPS. Defects that do not impair service shall not be cause for rejection. NAPPS assumes no liability in any event for consequential damages. No claim will be allowed for material damaged by the buyer or in transit. Defective equipment or parts shall be returned to NAPPS freight prepaid.

NAPPS will, at its option, repair, replace or refund the purchase price of products found by NAPPS to be defective in material or workmanship provided that written notice of such defect requesting instruction for repair, replacement or refund is received by NAPPS within ten (10) days of determination of said defect, but not more than one (1) year after the date of shipment, and provided that any instructions given thereafter by NAPPS are complied with.

Any products covered by this order found to NAPPS' satisfaction to be defective upon examination at NAPPS' factory will, at NAPPS' option, be repaired or replaced and returned to Buyer via lowest cost common carrier, or NAPPS may, at its option, grant Buyer a credit for the purchase price of the defective article.

Without limitation of the foregoing, this warranty shall not apply to (i) deterioration by corrosion or erosion of material or any cause or failure other than defect of material or workmanship; (ii) the performance of any system of which NAPPS' products are a component part; or (iii) any of NAPPS' products or parts thereof which have been subjected to alteration or repair by anyone other than NAPPS or someone authorized by NAPPS, or subjected to misuse, neglect, free chemicals in system, corrosive atmosphere, abuse or improper use or misapplication such as breakage by negligence, accident, vandalism, the elements, shock, vibration or exposure to any other service, range or environment of greater severity than that for which the products were designed, or if operation is contrary to NAPPS' or manufacturer's recommendation, or if the serial number has been altered, defaced or removed.

Hermetic motor/compressors furnished by NAPPS are subject to the standard warranty terms set forth above, except that the hermetic motor/compressor replacements or exchanges shall be made through the nearest authorized wholesaler of the hermetic motor/compressor manufacturer (not NAPPS' factory) and no freight shall be allowed for transportation of the hermetic motor/compressor to and from the

wholesaler. For Trane hermetic motor/compressors, the nearest wholesaler referred to herein shall be the nearest Trane Parts Center. The replacement hermetic motor/compressor shall be identical to the model of the hermetic motor/compressor being replaced. Additional charges, which may be incurred through the substitution of other than identical replacements, are not covered by this warranty.

THE WARRANTY PROVIDED ABOVE IS THE ONLY WARRANTY MADE BY NAPPS WITH RESPECT TO ITS PRODUCTS OR ANY PARTS THEREFORE AND IS MADE EXPRESSLY IN LIEU OF ANY OTHER WARRANTIES, BY COURSE OF DEALING, USAGES OF TRADE OR OTHERWISE, EXPRESSED OR IMPLIED, INCLUDING BUT NOT LIMITED TO ANY IMPLIED WARRANTIES OF FITNESS FOR ANY PARTICULAR PURPOSE OR OF MERCHANTABILITY UNDER THE UNIFORM COMMERCIAL CODE. IT IS AGREED THAT THIS WARRANTY IS IN LIEU OF AND BUYER HEREBY WAIVES ALL OTHER WARRANTIES, GUARANTEES OR LIABILITIES ARISING BY LAW OR OTHERWISE. NAPPS SHALL NOT INCUR ANY OTHER OBLIGATIONS OR LIABILITIES OR BE LIABLE TO BUYER OR ANY CUSTOMER OF BUYER FOR ANY ANTICIPATED OR LOST PROFITS, INCIDENTAL OR CONSEQUENTIAL DAMAGES, OR ANY OTHER LOSSES OR EXPENSES INCURRED BY REASON OF THE PURCHASE, INSTALLATION, REPAIR, USE OR MISUSE BY BUYER OR THIRD PARTIES OF ITS PRODUCTS (INCLUDING ANY PARTS REPAIRED OR REPLACED); AND NAPPS DOES NOT AUTHORIZE ANY PERSON TO ASSUME FOR NAPPS ANY OTHER LIABILITY IN CONNECTION WITH THE PRODUCTS OR PARTS THEREFORE. NAPPS SHALL NOT BE RESPONSIBLE FOR THE LOSS OR REPLACEMENT OF OR THE ADDITION OF COMPRESSOR OIL, OR REFRIGERANT. THIS WARRANTY CANNOT BE EXTENDED, ALTERED OR VARIED EXCEPT BY A WRITTEN INSTRUMENT SIGNED BY NAPPS AND BUYER.

II. LIMITATION OF LIABILITY

NAPPS shall not be liable, in contract or in tort, for any special, indirect, incidental or consequential damages, such as, but not limited to, loss of profits, or injury or damage caused to property, products, or persons by reason of the installation, modification, use, repair, maintenance or mechanical failure of any NAPPS product.