

MODEL	OPERATING WEIGHT	SHIPPING WEIGHT
NCC-15	825 LBS	965 LBS
NCC-20	875 LBS	1010 LBS
NCC-26	1145 LBS	1275 LBS
NCC-30	1285 LBS	1410 LBS

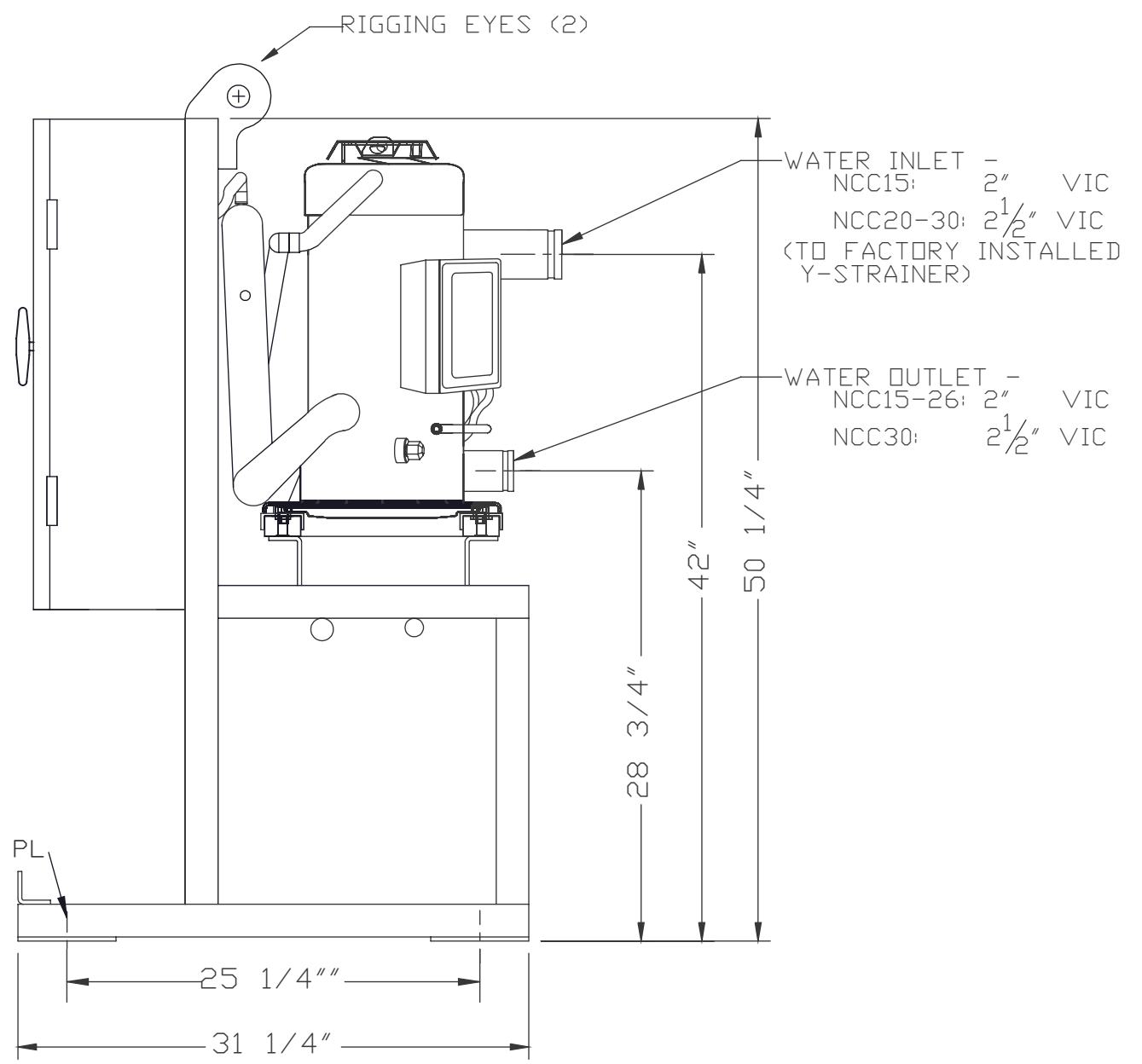

NOTES:

1. Allow 36" clearance on control box side for service.
2. Allow 24" min at rear to allow for service of compressors.
3. Allow 36" service clearance overhead.

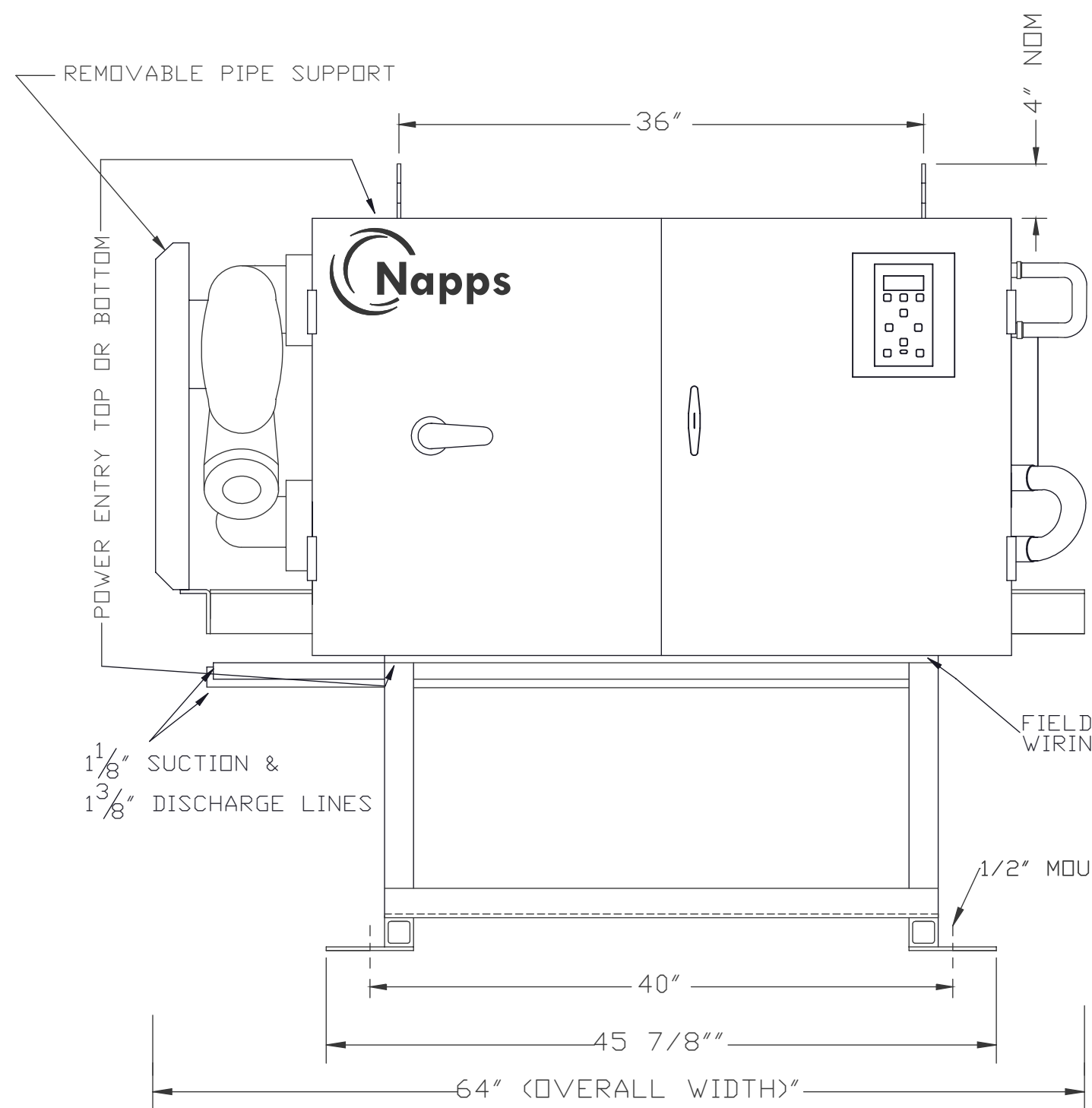

**IMPORTANT**  
 THE INFORMATION CONTAINED HEREON, WHICH IS THE PROPERTY OF NAPP'S TECHNOLOGY CORPORATION, MUST BE MAINTAINED IN STRICT CONFIDENCE AND NO PORTION OF THIS MATERIAL MAY BE REPRODUCED OR USED FOR ANY PURPOSE WITHOUT THE EXPRESS WRITTEN CONSENT OF NAPP'S TECHNOLOGY CORPORATION.

ENGINEER'S SEAL	#	BY	DATE	REVISION
	1	SMH	04-02-12	Corrected operating wts, added shipping wts & overhead clearance

**Napps** NAPP'S TECHNOLOGY CORP.  
 P.O. BOX 3066  
 LONGVIEW, TX 75606-3066  
 WWW.NAPPSTECH.COM

TITLE: TYP NCC 15,20,26,30 TON  
 SCROLL COMPRESSOR CHILLER

SCALE: FULL DRAWN BY: CHECKED BY: APP'D BY:  
 DATE: 04/04/2011 AMS PMK

R410A-UNITS B

DRAWING NUMBER REV. SHEET NO. NAPP'S JOB NO.  
 NCC15202630 01 1 OF 1